

® SAFETOR ROOF ANCHORS

... when your life is on the line!!

Safetor Height Safety Poly Panel Anchors are compliant to the AS/NZS 5532.2013 anchor testing Standard.

SPP-TA Safetor Poly Panel - Trapezoidal Anchor

Safetor Height Safety Poly Panel Anchors Will:

1. Reduce loading on the Poly Panels if a fall occurs
2. Absorbs energy without becoming brittle through stress loading or cold temperatures
3. Survive in the most severe environments without rusting or corroding
4. Comply to all building codes and standards
5. Safetor Anchors exceed the testing mandate. This is well-proven and fully documented
6. Our range of Poly Panel anchors are manufactured in New Zealand



SPP- TA

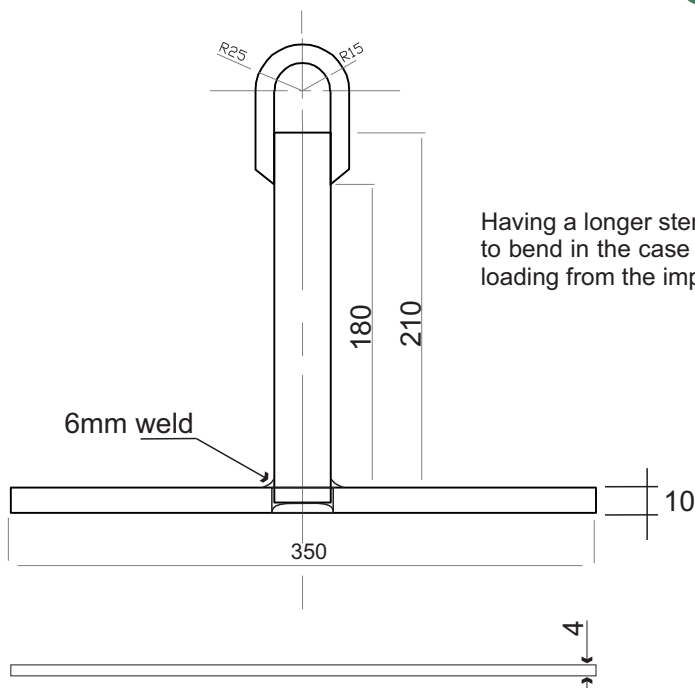

Having a longer stem on the anchor allows the anchor to bend in the case of a fall. This will reduce the full loading from the impact on the poly panel

Please note:
Mounting hole placement to suit roofing profile

® SAFETOR ROOF ANCHORS

... when your life is on the line!!

Safetor Height Safety Poly Panel Anchors are compliant to the AS/NZS 5532.2013 anchor testing Standard.

SPP-TA Safetor Poly Panel Height Safety anchor Structural attachment Detail

Rated for 1 person @ 15kN

**NB: Never work in Fall-Arrest
Always work in Restraint**

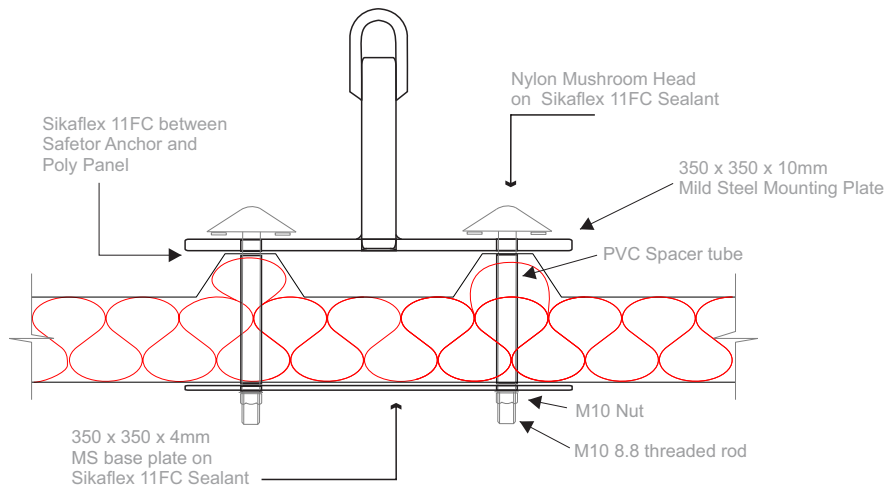

Rated for 2 person @ 21kN

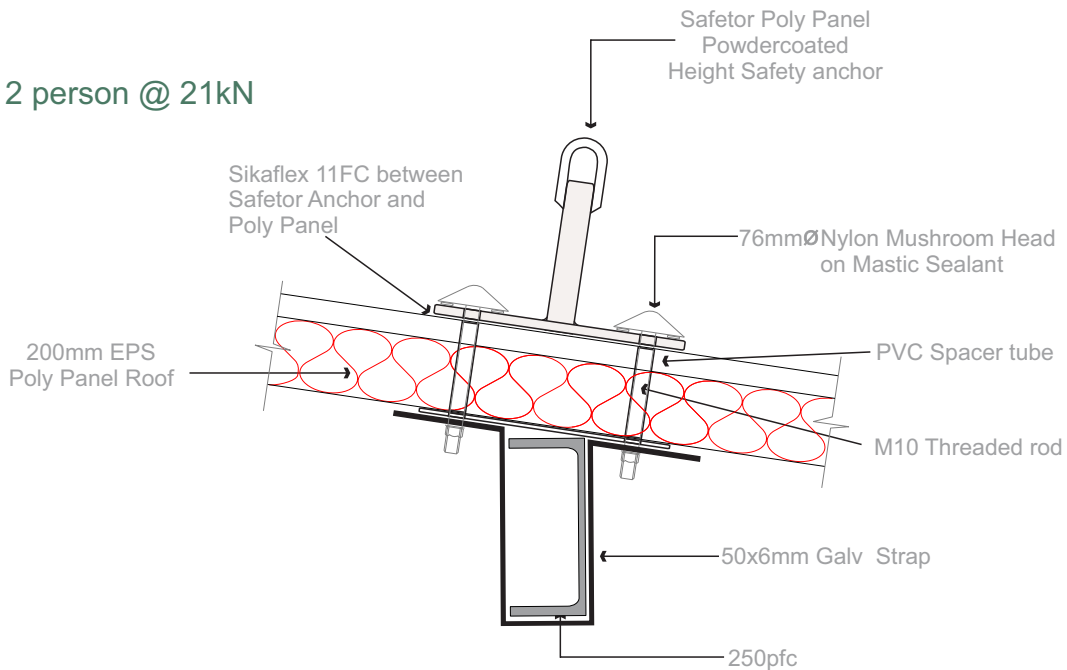

Installation:

The installation should only be carried out by a competent person as set out in the AS/NZS 1891.4:2009 Standards. It is the responsibility of the installer to supply to the building owner clear instructions as per the AS/NZS1891.2.2001 section 5.3 Installed systems A & B and a maintenance program for the care of their height safety anchor points. It is the responsibility of the Installer, Building Designer or Building Owner to ensure that the structure to which the anchor is attached to will support a load of at least 15kN as set out in the AS/NZS 1891.4:2009 Standards.

NB:

It is the responsibility of the installer to obtain a PS1 from a IPENZ Structural Engineer before installing any height safety anchor points and upon completion a PS3 or PS4 must be signed off to state the anchor has been installed as per the PS1.



Product Safetor Roof Anchors
Company Collins Corporation Ltd

Product Description

Safetor Roof Anchors have been specifically designed to provide safe anchors for safety lines that can be applied to a wide range of building sizes, roof shapes and construction modes.

This Poly Panel roof anchor has been tested to the AS/NZS 5532.2013 Anchor testing standard and meets the AS/NZS 1891.4:2000. The AS/NZS 1891.4:2000. is only a the maintenance standard and not a testing standard.

Scope of Use

SAFETOR Roof Anchors are designed to protect and save lives while people are working at height, giving them a solid point to attach safety lines for fall-restraint, fall-arrest and abseil.

Care must be taken when using any Safetor Roof Anchors.

Statement of Building Code Compliance

This product if designed, used, installed and maintained in accordance with the supporting technical information and additional conditions and limitations will meet the following provisions of the New Zealand Building Code:

- AS/NZS 5532 : 2013 (Anchor Point Testing)
- AS/NZS 1891.4: 2009 (Anchor Points)
- AS/NZS 1891.2: 2001 (Horizontal Lifeline and Rail Systems)
- AS/NZS 4488.1 & 2: 1997 (Industrial Rope Access Systems)
- NZBC-Clause B1 Structure,B2 Durability, F4 Safety from Falling
- NZ - BCA (Performance-based Building Code)
- AS/NZS 1170 (Structural Design Actions)
- AS/NZS 4600 (Cold Formed Steel Structures)
- NZS 3604 (Timber Framed Buildings)
- NZS 3404 (Steel Structures)



Evidence base to support compliance

This product has the following evidence to support the above solution type declaration:

- In-house technical opinion
- Appraisal
- Independent testing

The Anchors have been tested to: AS/NZS 5532.2013 Standard by:

1. QSI who are an Accredited IANZ testing Laboratory and also certified ISO testing facility.
2. MTL who are an Accredited IANZ testing Laboratory MTL who are an IANZ approved Laboratory.

SPP- TA

Safetor anchors meet all anchor testing standards

Validity Date

The validity date is dictated by the earliest renewal date of any relevant testing or appraisal documents. 26/06/2015

Installation Conditions

This product is code-compliant on the condition that it has been installed by: a Competent Person